



BRIDGEVIEW

BALE KING V-RAKE VR810 Assembly Manual

8 Wheel Rake/10 Wheel Extension Kit



Bridgeview Manufacturing Inc.

**P.O. Box 4
Gerald, SK
S0A 1B0
(306) 745-2711**



Table of Contents

1.0	Introduction.....	1
2.0	Parts List	1
2.1	8 Wheel Rake – Parts List.....	1
2.2	10 Wheel Extension Kit – Parts List.....	4
2.3	Side Caster – Parts List	4
3.0	Part Drawings.....	5
4.0	Safety	8
5.0	Tools required	8
6.0	Fastener Information	8
7.0	Assembly Procedure	9
7.1	Install Rear Frame	9
7.2	Install Rear Jack.....	11
7.3	Running Hydraulic Hoses - Main Body and Gooseneck	11
7.4	Install Gooseneck.....	12
7.5	Install Knuckles	13
7.6	Install Rake Arms	14
7.6.1	Optional 10 Wheel Extension	15
7.7	Install Wrap Around Caster Extension	15
7.8	Rear Hub Assembly & Tires.....	15
7.9	Install Caster Assembly	16
7.10	Install Front Hub & Tire	17
7.10.1	Install Optional Caster Mounting Bracket	18
7.10.2	Install Caster Assembly to Mounting Bracket	19
7.11	Install Hitch Jack.....	19
7.12	Install Riser Arms	19
7.13	Install Frame Slides.....	20
7.14	Insert Hydraulic Ram.....	21
7.15	Rear Scissor Arm	21
7.16	Front Scissor Arm	22
7.17	Lift Rod Cylinders	23
7.18	Install Lift Rods	23
7.18.1	Install Lift Rod Extenders.....	23
7.19	Running Hoses to Lift Rod Cylinders.....	24
7.20	Install Rake Wheel Mounting Arm.....	25
7.21	Install Spring Assembly to Mounting Arm.....	25
7.22	Install Rake Wheels	26
7.23	Torque Settings	26



1.0 Introduction

This manual describes the materials and assembly process in order to assemble the Bridgeview 8 Wheel Rake and optional 10 Wheel Extension Kit. Please read through this manual before beginning assembly.

2.0 Parts List

Before assembly, ensure that all of the components are included. The parts list for the Bridgeview 8 Wheel Rake and optional 10 Wheel Extension Kit is available below.

2.1 8 Wheel Rake – Parts List

Assembled Parts

- 4 – Rake Wheel Left
- 4 – Rake Wheel Right
- 8 – Spring Assembly
- 2 – Rear Hub Assembly

Main Body (Parts)

- 1 – Gooseneck
- 1 – Main Hitch Beam (Main Frame)
- 1 – Rear Frame – Left
- 1 – Rear Frame – Right
- 2 – Rear Frame Clamp Plate
- 2 – Rear Jack – Pin
- 1 – Rear Jack
- 1 – Left Knuckle
- 1 – Right Knuckle
- 4 – Knuckle Pin
- 1 – Rake Arm – Left
- 1 – Rake Arm – Right
- 1 – Wrap-around Caster Mount – Left
- 1 – Wrap-around Caster Mount – Right
- 1 – 5000 lb. Jack
- 2 – Transport Link
- 2 – Hose Clip
- 1 – Hose Kit
- 1 – Hose Adaptor Kit



Main Body (Bolt List)

- 9 – 5/8" x 1 3/4" with Serrated Flange Nuts – Gooseneck Flange
- 8 – 5/8" x 1 3/4" with Serrated Flange Nuts – Rear Hub Attachment
- 12 – 5/8" x 1 3/4" with Serrated Flange Nuts – Wrap-around Caster Mounts
- 8 – 5/8" x 1 3/4" with Nuts and Locking Washers – Rear Clamp Plates
- 2 – 3/8" Nylon Locking Nuts – Hose Clips
- 2 – 1/4" x 2" Cotter Pin – Rear Jack Pins
- 6 – 5/8" x 3 1/2" Bent Pins with 5/32" x 2 15/16" Hair Pin – For Transport Links
- 1 – Jack Pin with 3/32" x 2" Hair Pin – Front Hitch Jack
- 4 – Male Hydraulic Tips
- 2 – 5/32" x 2 15/16" Hair Pins – For Transport Link Holders
- 10 – Rear Wheel Bolt

Scissor Arm (Parts)

- 1 – Riser Arm – Left
- 1 – Riser Arm – Right
- 1 – Hydraulic Cylinder (2.5" x 30")
- 1 – Cylinder Pin (Base End)
- 1 – Cylinder Pin (Ram End)
- 2 – Scissor Arm Frame Slide – Top Plate
- 1 – Scissor Arm Frame Slide – Bottom Plate Front
- 1 – Scissor Arm Frame Slide – Bottom Plate Rear
- 4 – Scissor Arm Frame Slide – Pin
- 2 – Riser Arm Center Pin
- 4 – Riser Arm Washer
- 2 – Scissor Arm Front
- 2 – Scissor Arm Rear

Scissor Arm (Bolt List)

- 8 – 1/2" x 1 1/2" With Nylon Locking Nuts – Attaching Bottoms to Frame Slides
- 8 – 1/4" x 2" Roll Pin – Scissor Arm Attachment to Frame Slides
- 2 – 1/4" x 2" Cotter Pin – Attaching Main Cylinder Pins
- 4 – 3/4" x (5x6 1/2") Square U-Bolts – To Attach Riser Arms
- 8 – 3/4" Serrated Flange Nuts – To Attach Riser Arms

Lift Rod (Parts)

- 2 – Threaded Rod Adjusters
- 4 – Lift Rod Adjuster Nut
- 2 – Hydraulic Cylinder (1" x 8")
- 2 – Cylinder Safety Lock with PTO clips
- 2 – Main Lift Rod



Lift Rod (Bolt List)

- 4 – 1/2" x 2 1/4" with Nylon Locking Nuts – Lift Rod Coupler
- 8 – 1.125 ID Plastic Bushings – For Lift Rod Assembly

Front Caster (Parts)

- 2 – Caster
- 2 – Caster Axle
- 2 – Brake Disk
- 2 – Bottom Brake Pad (w/ bolt)
- 2 – Top Brake Pad
- 2 – Caster Tear Drop
- 2 – Caster Spindle Spacer Large
- 2 – Caster Spindle Spacer Small
- 2 – Caster Wheel Hub w/cups
- 4 – Caster Hub Cones
- 4 – Caster Wheel Seal

Front Caster (Bolt List)

- 2 – 3/8" x 2 3/4" Roll Pin - Caster Pivot Mount
- 2 – 1 1/4" Castle Nut with 1/4" x 2" Cotter Pins – Caster Axle
- 4 – 3/8" x 1 3/4" with Nylon Locking Nuts – Caster Axle Retainer
- 2 – 1/2" Nylon Locking Nut – Brake Disk
- 2 – .321 x .888 ID x 2 Spring with washer – Brake Spring
- 10 – Caster Wheel Nuts (90 Degree Tapered Edge) Fine Thread

Rake Wheel Mount (Parts)

- 4 – Rake Wheel Arm – Left
- 4 – Rake Wheel Arm – Right
- 8 – Rake Wheel Arm Washer

Rake Wheel Mount (Bolt List)

- 8 – 1/4" x 2" Roll Pin – Attaching Rake Wheel Arms
- 8 – 1/2" x 1 3/4" with Nylon Locking Nut – Mounting Rake Wheel Springs
- 32 – Rake Wheel Nuts (60 Degree Tapered Edge) Fine Thread

Misc.

- 20 – 1/4" Grease Zerk (8 are installed, 8 in Rake Wheels, 4 in Tire Hubs)
- 4 – 1/4" 90 Degree Grease Zerk



2.2 10 Wheel Extension Kit – Parts List

Assembled Parts

- 2 – Spring Assembly
- 1 – Rake Wheel – Left
- 1 – Rake Wheel – Right

Parts List

- 1 – Frame Extension – Left
- 1 – Frame Extension – Right
- 2 – Lift Rod Extension
- 1 – Rake Wheel Arm – Left
- 1 – Rake Wheel Arm – Right
- 2 – Rake Wheel Arm Washer

Bolt List

- 12 – 5/8" x 1 3/4" with Serrated Flange Nuts – Rake Arm Extension
- 2 – 1/2" x 2 1/4" with Nylon Locking Nuts – Lift Rod Coupler
- 2 – Bushing Lift Rod Slide
- 2 – 1/4" x 2" Roll Pin – Attaching Rake Wheel Arms
- 2 – 1/2" x 1 3/4" with Nylon Locking Nut – Mounting Rake Wheel Springs
- 4 – 1/4" Grease Zerk

2.3 Side Caster – Parts List

Assembled Parts

- 2 – Caster Wheels

Parts List

- 2 – Caster tear drop
- 2 – Caster
- 2 – Clamp on Caster Mount
- 2 – Caster Axle
- 2 – Brake Disk
- 2 – Bottom Brake Pad (w/ bolt)
- 2 – Top Brake Pad
- 2 – Caster Wheel Hub
- 2 – Caster Spindle Spacer Large
- 2 – Caster Spindle Spacer Small

Bolt List

- 2 – 1 1/4" Castle Nut with 1/4" x 2" Cotter Pins – Caster Axle
- 4 – 3/8" x 1 3/4" with Nylon Locking Nuts – Caster Axle Tear Drops
- 2 – 1/2" Nylon Locking Nut – Brake Disk
- 2 – .321 x .888 ID x 2 Spring with washer – Brake Spring
- 2 – 1/4" Grease Zerk
- 4 – 3/4" x (5x6 1/2") Square U-Bolts w/ Serrated Flange Nuts – Attach Caster Mount



3.0 Part Drawings

Below are drawings for the main parts of the VR810 V-Rake.

Note: Drawings are not scaled!

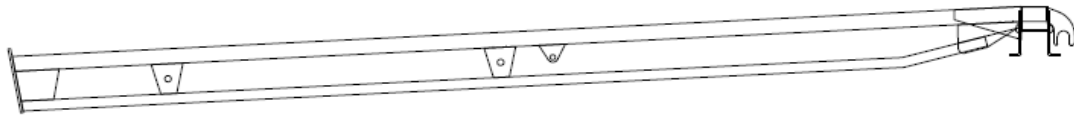

Main Hitch (Main Frame)

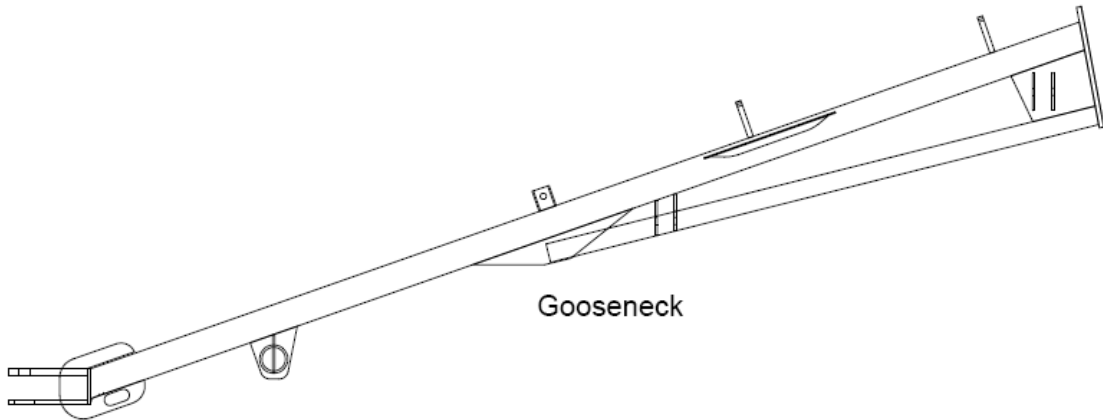

Gooseneck

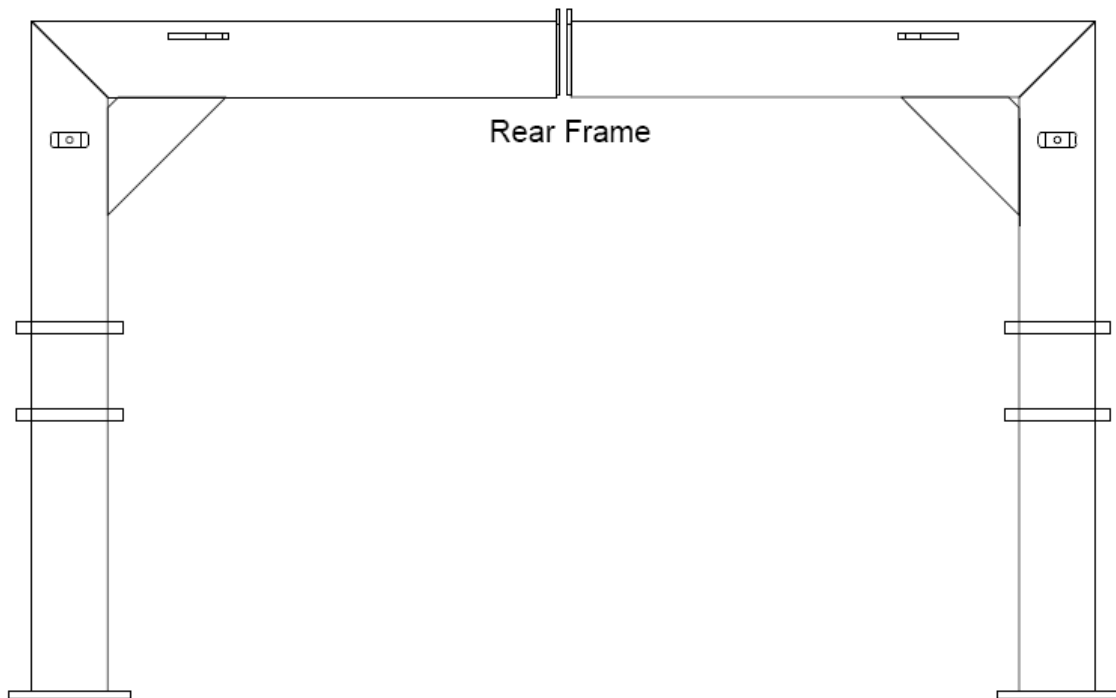

Rear Frame



Note: Drawings are not scaled!

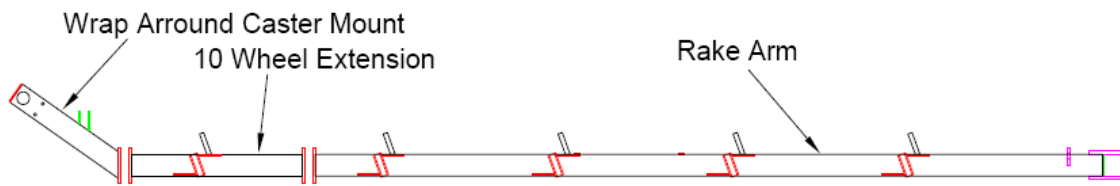

Front Scissor Arm Long

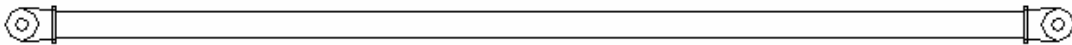

Rear Scissor Arm Short

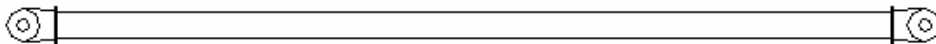

Lower Caster Assembly

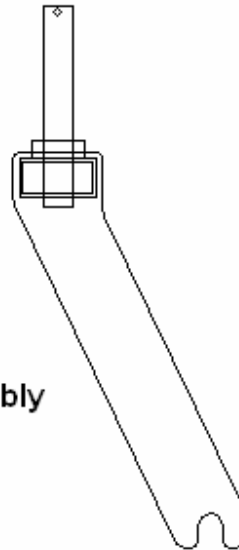



Note: Drawings are not scaled!

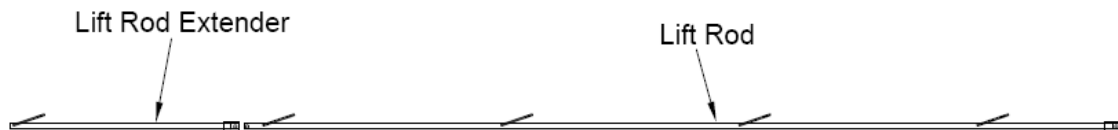
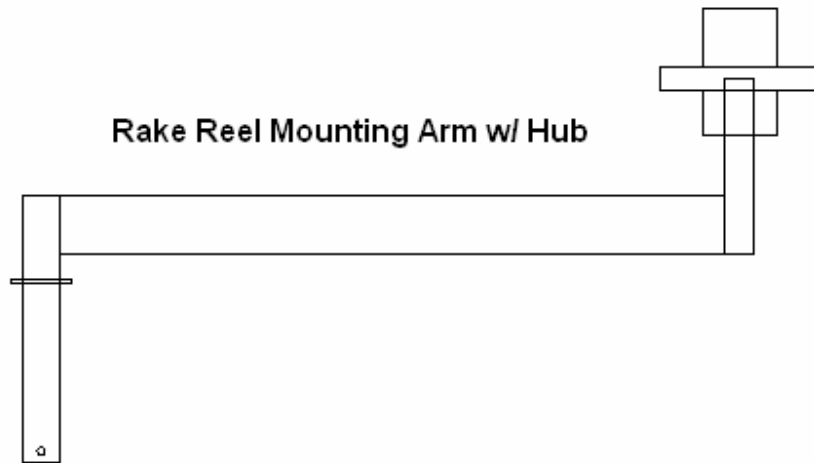
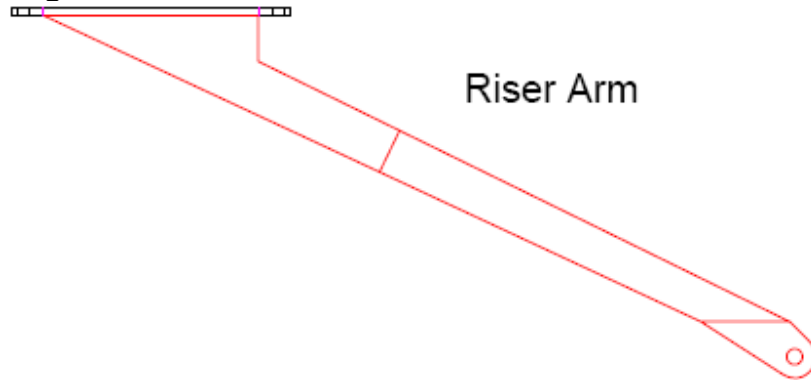



4.0 Safety

Proper precautions must be taken to ensure safe assembly of the Bridgeview 8 Wheel Rake and optional 10 Wheel Extension Kit:

- Wear proper safety equipment when assembling the rake. Steel toe boots and safety glasses are required. Earplugs are recommended when tightening bolts.
- Gloves are recommended when handling materials.
- Be sure to have solid working platforms during assembly to ensure the work pieces are stable.
- Always have help when lifting heavy pieces.

5.0 Tools required

The following tools are required for the assembly of the Bridgeview 8 Wheel Rake and optional 10 Wheel Extension Kit:

- Forklift or Hoist
- Impact Wrench
- Tape Measure
- Basic Hand Tools

6.0 Fastener Information

Your Bridgeview Rake is fastened with a variety of bolts. For these bolts to work properly the correct washer and nut must be used in the proper situation. Please consult this guide for correct fastener information. Also ensure that all fasteners are securely tightened. Serrated flange nuts must be installed tightly with an impact wrench. The flanged nut must be tight against the steel in order for the nut to correctly bind.



7.0 Assembly Procedure

The following is the standard procedure used to assemble the Bridgeview 8 Wheel Rake and optional 10 Wheel Extension Kit.

NOTE: Left and Right, as referred to in this guide, are taken as if you are standing at the rear of the rake, looking along the length of the rake towards the tractor hitch.

7.1 Install Rear Frame

The first step in assembly is to install the rear frame pieces to the main body. The rear frame is made of two pieces, a left rear frame and a right rear frame. The left and right can be distinguished by the knuckle bracket. This bracket will face towards the main body of the rake on both the left and right rear frames.

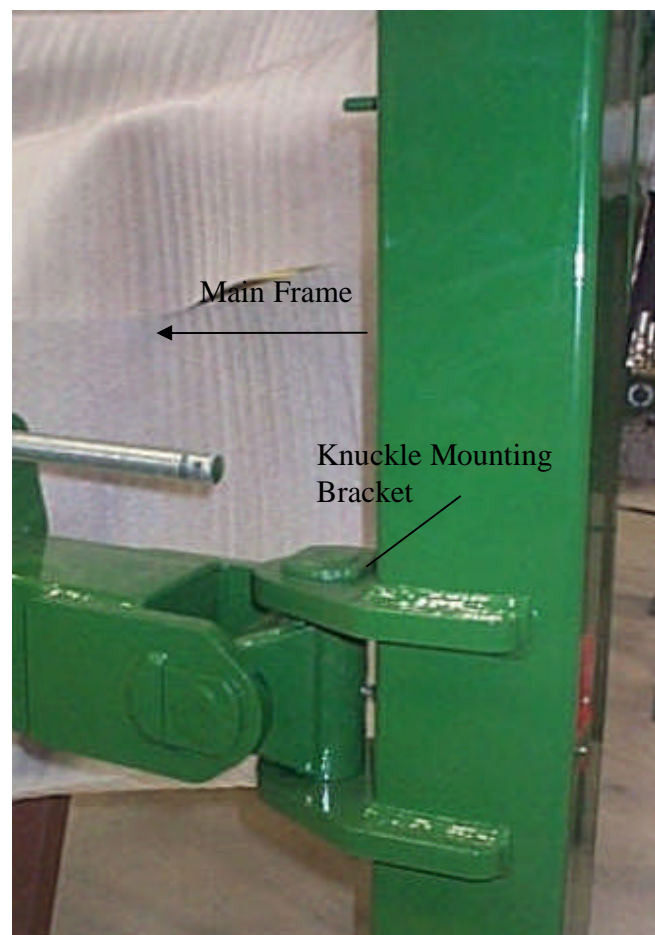



Insert either the left or right rear frame into the main hitch ensuring that the knuckle mounting bracket is facing towards the main body. The inside edge of the rear frame should be about 3 inches from the center of the main hitch.

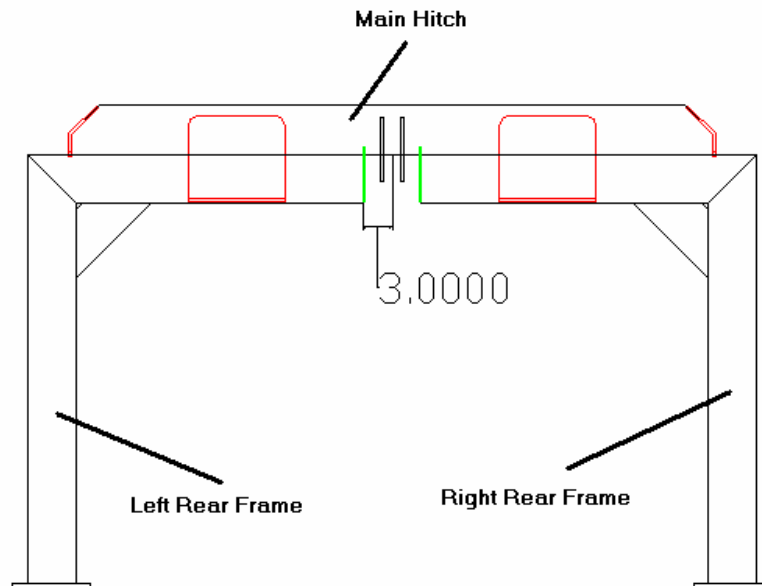

Secure the rear frame to the main hitch using the clamp plate and hand tighten the four 5/8" x 1 3/4" bolts with 5/8" nuts and locking washers. **DO NOT TIGHTEN THE CLAMP PLATE.** At this point, the clamp plate must remain loose enough so that the sides of the rear frame can be slid left and right.

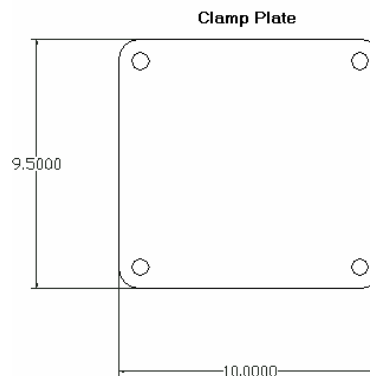

Repeat this procedure for the other half of the rear frame.

Once you have both sides of the rear frame installed ensure that they are spaced approximately 3 inches from the center of the rake (6 inches from each other).



7.2 Install Rear Jack

If the rear frames have been spaced 3 inches from center, the length of the rear jack should be pre-set to fit directly onto the mounting points of rear frames. The jack should be lifted into place and secured to the rear frames using the rear jack pins (1" dia. x 1 7/8" L) with a 1/4" x 2" cotter pin.

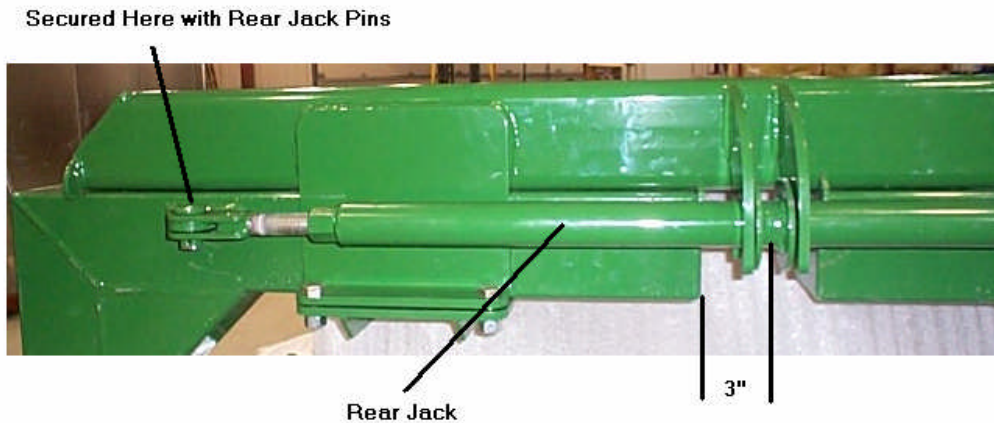

Once the Rear Jack is in place, the clamp plates for the rear frame can be tightened.

7.3 Running Hydraulic Hoses - Main Body and Gooseneck

Now the four long hydraulic hoses (labeled VR1, VR2 & VR3) can be run through the main body of the rake. Place the rake so that it is sitting upright with the rear end of the rake sitting on the bottom of the rear frame. Run the hoses from the open end of the main body towards the rear of the rake. The hoses must be run with the wrench end going into the rake. There are two holes in the bottom of the main body, one just past the center of the main body, and one at the rear of the rake. The two shorter hoses (VR1 & VR2) will exit out the hole near the center while the two longer hoses (VR3) will exit the hole at the rear.

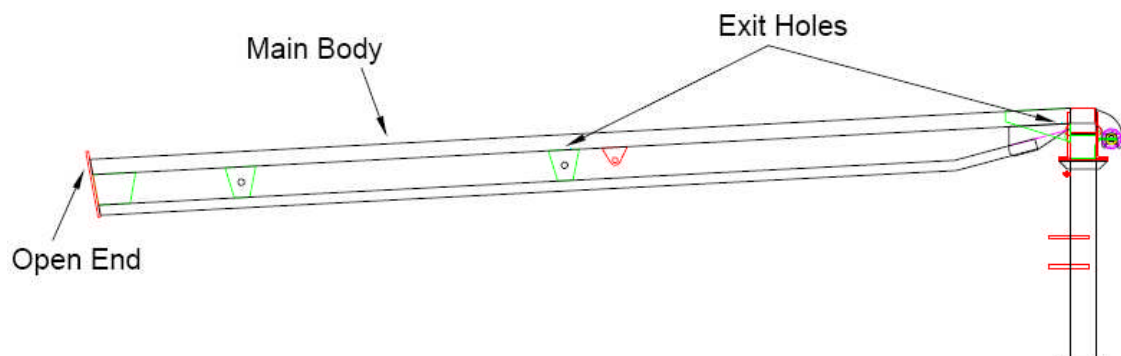



Once the hoses have been run through the main body they must be run through the gooseneck. Place the open end of the gooseneck near the open end of the main body and run the hoses from the open end of the main body through the gooseneck to the opening in the gooseneck near the hitch. There should be a few feet of hose sticking out the opening at the front of the gooseneck. Once the hoses have been run through the gooseneck the gooseneck can be attached to the main body.

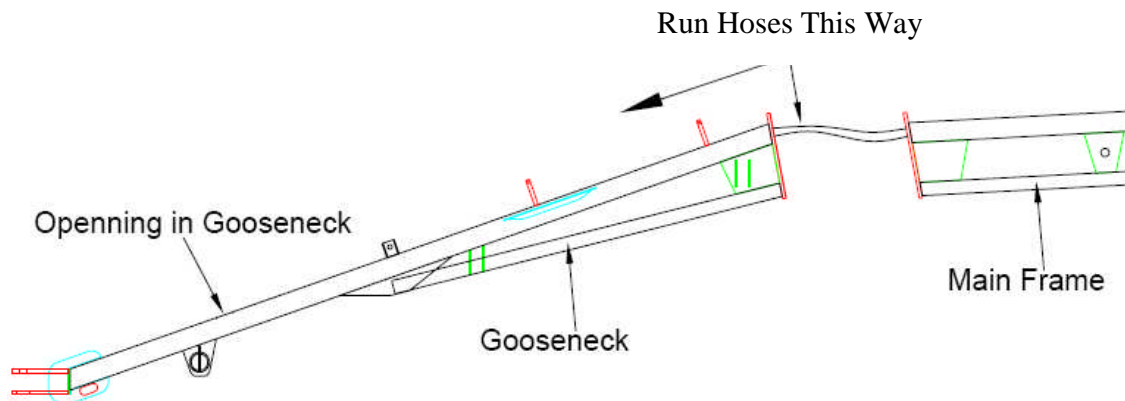

7.4 Install Gooseneck

The gooseneck is attached to the main body using 5/8" x 1 3/4" bolts and serrated flange nuts. While attaching the gooseneck ensure that the hydraulic hoses do not interfere. Secure the gooseneck tightly to the main body.



7.5 Install Knuckles

There are two knuckles to be installed, a left and a right. The knuckles are marked with an "L" or "R" to designate Left and Right. The knuckles can also be distinguished by the offset angle. The picture below shows how the knuckles are offset. The knuckles will be used to attach the rake arms to the rear frame. Make sure to install the grease zerks before installing knuckles (the zerks are self tapping).

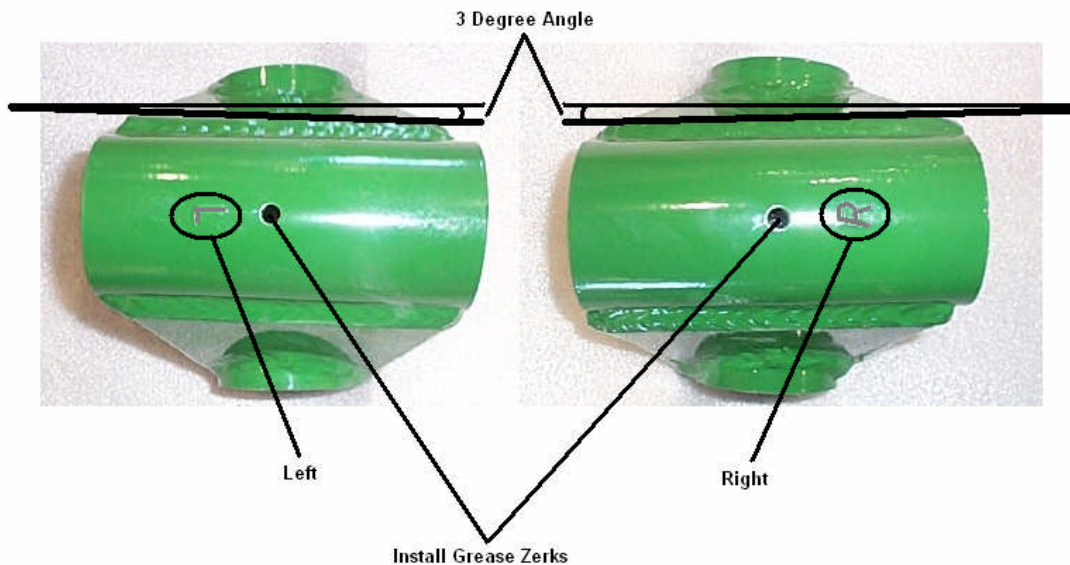

To install, place the left knuckle into the left mounting bracket of the rear frame. The left knuckle can be inserted either way, as long as it is inserted on the left side of the rear frame. Repeat this procedure for the right hand side. The tilt of the knuckle should cause the rake arm to lean slightly towards the outside. Below is an exaggerated picture of the knuckle angle.

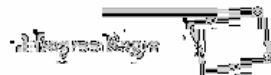



Slide the pin through the mounting bracket and the knuckle. The pins should be inserted so that the pin retainer is located on the top of the rear frame, and on the outside of the rake arm.



Knuckle Mounting Bracket

Secure the pin with a 1/4" x 2" role pin through the pin hole.

7.6 Install Rake Arms

Place the front end of the rake arm on saw horse. The rake arms should be installed with the riser arm stoppers to the inside and the lift rod holder on top.

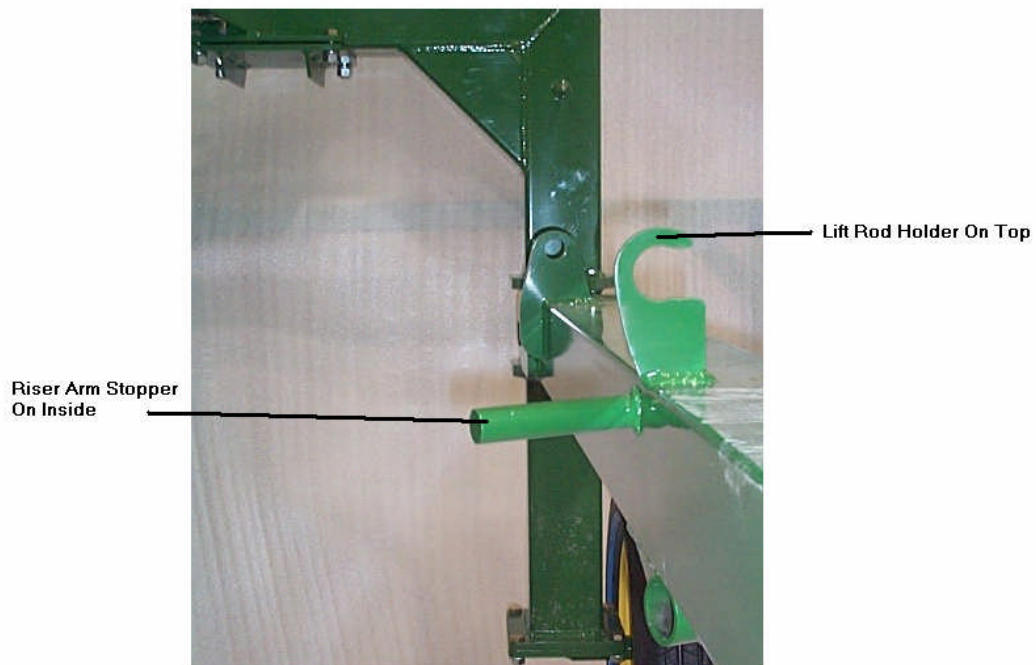

Lift the rear end of the rake arm up and slide it into the knuckle. Install the pin into the knuckle and secure pin with a 1/4" x 2" role pin through the pin hole.



7.6.1 Optional 10 Wheel Extension

If the optional 10 wheel extension was purchased, install the rake arm extender at this time. The rake arm extender is bolted to the open end of the rake arm. The rake arm extender is attached using 5/8" x 1 3/4" bolts using serrated flange nuts.

7.7 Install Wrap Around Caster Extension

This extension curves towards the inside of the frame. The pins on the extension should be facing up. This extension is attached to the end of the rake arm using 5/8" x 1 3/4" bolts using serrated flange nuts.

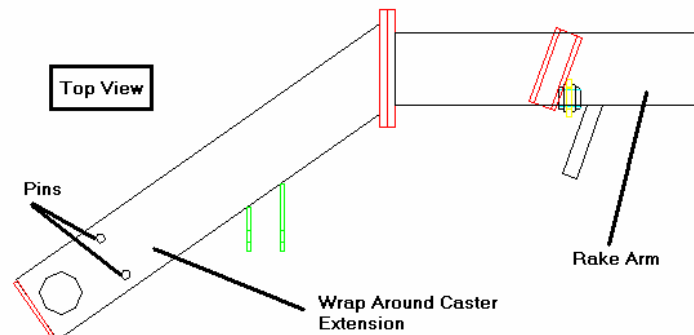

7.8 Rear Hub Assembly & Tires

Install the rear hub assembly to the bottom of the rear frames. There are two rear hub assemblies, one for each side of the rear frame. These assemblies are attached using 5/8" x 1 3/4" bolts with serrated flange nuts. Once the rear hub assemblies are attached, the tires can be mounted on the rear hubs.

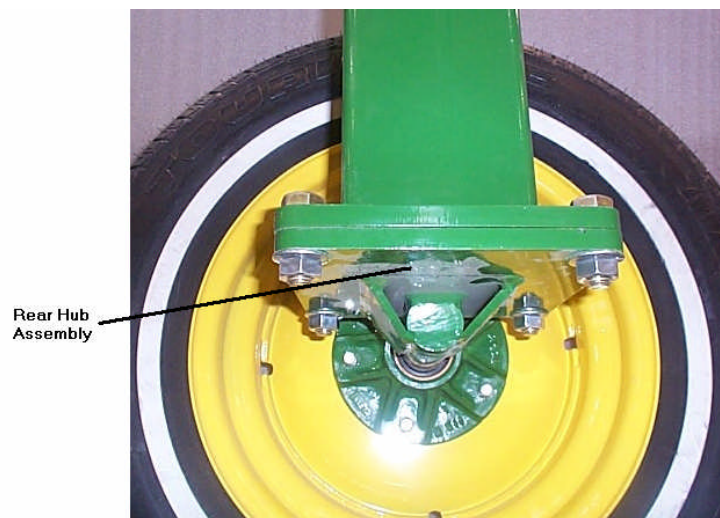



7.9 Install Caster Assembly

The caster assembly can be installed into the wrap around caster extension. Insert the lower caster assembly through the wrap around caster extension.

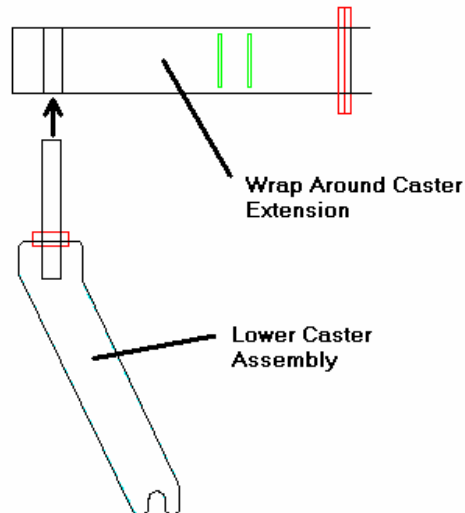

TIP: Cover the bushings with a light coat of grease for easier installation.

Install the bottom brake pad (the bottom pad has a bolt welded to it). This pad should be inserted over the dowel with the bolt facing up. Next install the brake disk and secure with a $3/8"$ x $2\ 3/4"$ roll pin. Then install the top brake pad. Finally install the brake spring and brake spring washer with a $1/2"$ nylon locking nut.

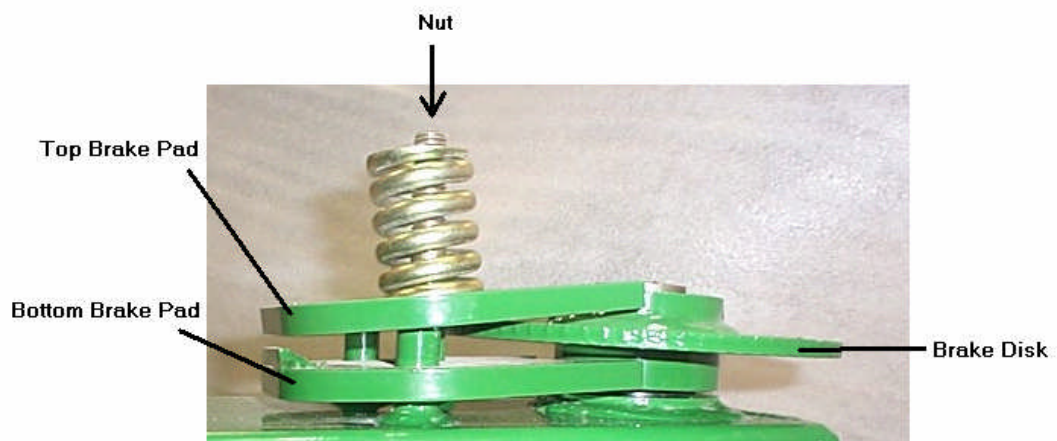



7.10 Install Front Hub & Tire

The front tires can now be mounted on the front casters. Grease and install the bearings into the hub of the tire. Mount the wheel to the hub using the appropriate nuts. The wheel should be mounted so the tapered edge of the nuts fit into the tapered holes of the wheel.

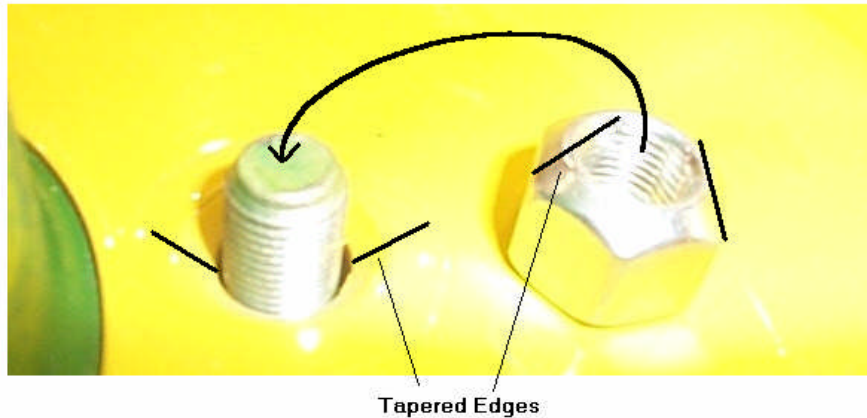

Next step is to install the axle to the wheel. The Diagram below shows the general layout for how the components of the axle should be mounted. NOTE: This diagram does not show the wheel mounted to the hub. The wheel must be mounted to the hub before installing in the caster!

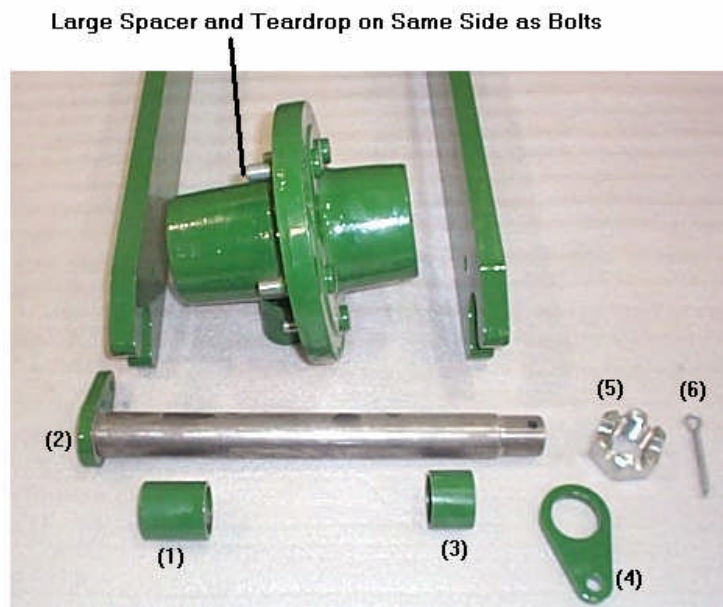

First the large spacer (1) is slid onto the axle (2). Install the axle into the hub with the large spacer and caster axle retainer on the side of the wheel that the nuts



are on. Next slide the small spacer (3) onto the axle. The axle can now be mounted to the caster arms. Turn the caster so that it is angled towards the end of the rake. Slide the axle into the wheel. The spacers will sit between the hub and the caster arms. The axle should be installed so that the caster axle retainer and the large spacer are to the outside of the rake. The caster axle retainer is secured to the outside of the caster with a 3/8" x 1 3/4" bolt and nylon locking nut. The slide on retainer (4) is installed to the other side of the caster and is also secured with a 3/8" x 1 3/4" bolt and nylon locking nut. Finally tighten the assembly with the castle nut (5) and secure the castle nut with a cotter pin (6).

Complete Assembly

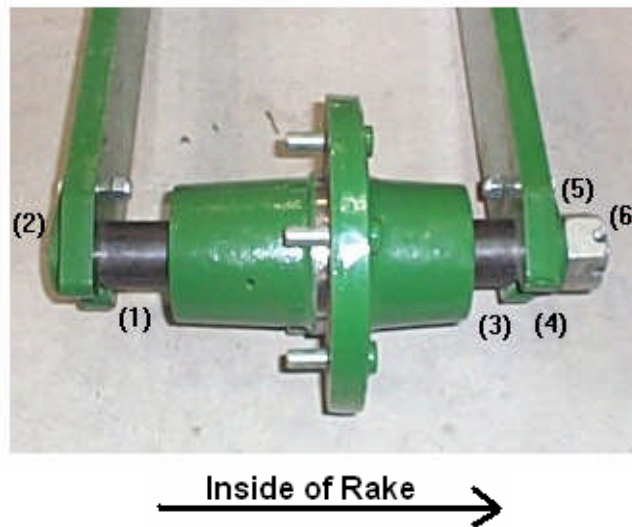

7.10.1 Install Optional Caster Mounting Bracket

If the optional 10 wheel extension kit was purchased the caster mounting bracket can be installed onto the rake arm. The mounting bracket is installed on the rake arm between the stop plates. These are located near the end of the rake arm. They are secured using 3/4" U-bolts and serrated flange nuts.

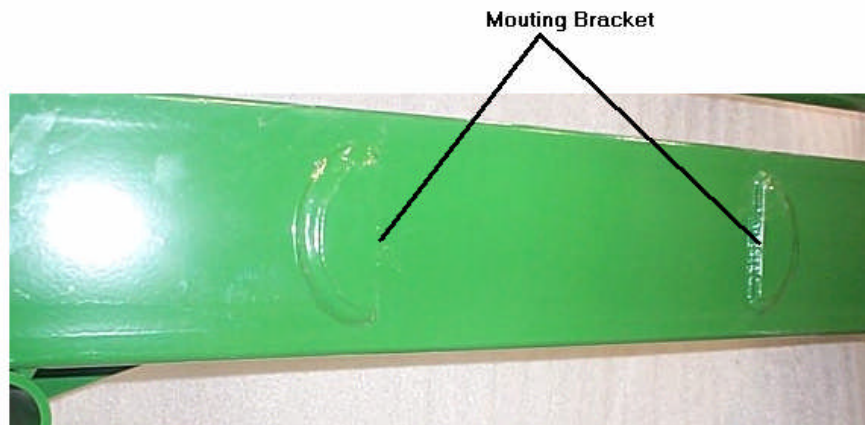



7.10.2 Install Caster Assembly to Mounting Bracket

The caster assembly can be installed to the mounting bracket. Follow the same procedure as in step 7.10.

7.11 Install Hitch Jack

Install the hitch jack to the gooseneck. The jack will slide onto the jack support on the gooseneck of the frame. The jack can now be used to support the Main Body on the ground.

7.12 Install Riser Arms

There are two riser arms for the rake, a left and right, and they will be mounted onto the rake arms. The riser arms are designed to angle up and to the back of the rake. Insert the arms into the mounting positions of the rake arms. Butt the flange against the Rake Wheel arm stopper and the flange stopper. Secure this with $\frac{3}{4}$ " U-bolts and serrated flange nuts.

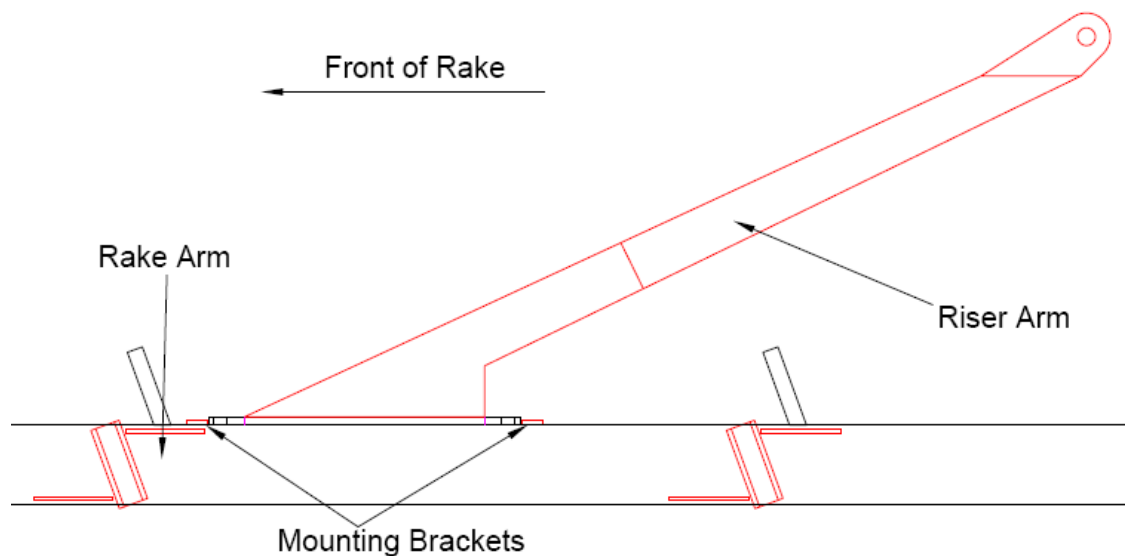



7.13 Install Frame Slides

There are two frame slides to be installed on the rake, a front and a rear. The front and rear frame slides have identical top pieces, but different bottom pieces. The rear frame slide has a mounting bracket on the bottom piece, while the front frame slide does not. The frame slides are mounted in the following positions on the frame: the front frame slide is mounted between the first and second frame supports, and the rear frame slide is mounted near the rear of the frame after the last frame support.

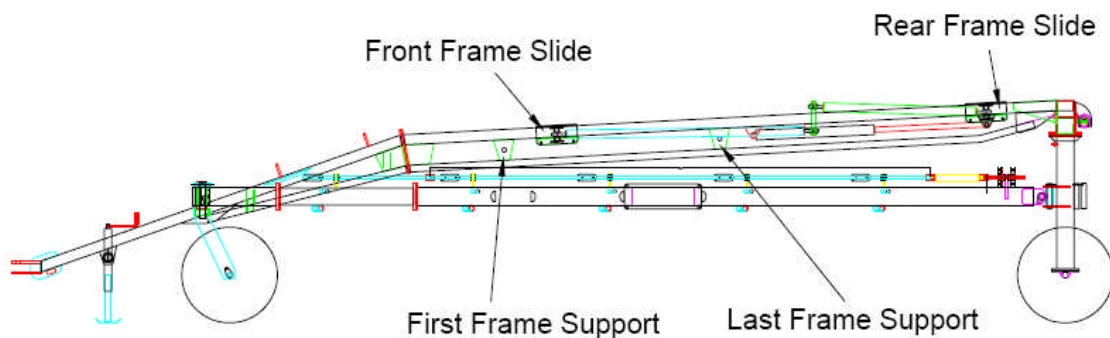

To install a frame slide, slip the top plate over the frame. Place the bottom plate under the frame and secure together using $\frac{1}{2}$ " x $1 \frac{1}{2}$ " bolts and locking nuts. Once installed the frame slides should slide easily on the frame.

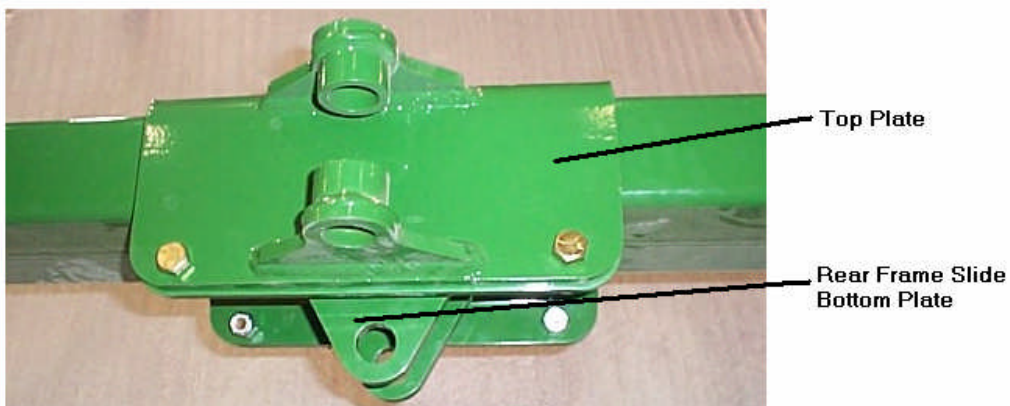



7.14 Insert Hydraulic Ram

The Hydraulic Ram for the rear Frame Slides can now be prepared and inserted. Mount the hydraulic 90 degree fittings to the cylinder. The cylinder is mounted in the middle of the Main Body. The base of the cylinder (main cylinder) is attached to the mounting point near the middle of the body. The ram of the cylinder (extendable end) is mounted to the bottom of the rear Frame Slides. Mount the cylinder using the appropriate pins with $\frac{1}{4}$ " x 2" cotter pins. To install the hydraulic hoses, insert the orifice fitting into the opening for the hydraulic attachment at the base end of the cylinder. Next install the 90 degree fittings to the cylinder. Attach the two hydraulic hoses from the center of the main body to the cylinder. The hose labeled VR1 will attach to the base, and the hose labeled VR2 will attach near the ram. The hoses should attach to the bottom of the cylinder. To prepare the cylinder, fully extend the cylinder shaft.

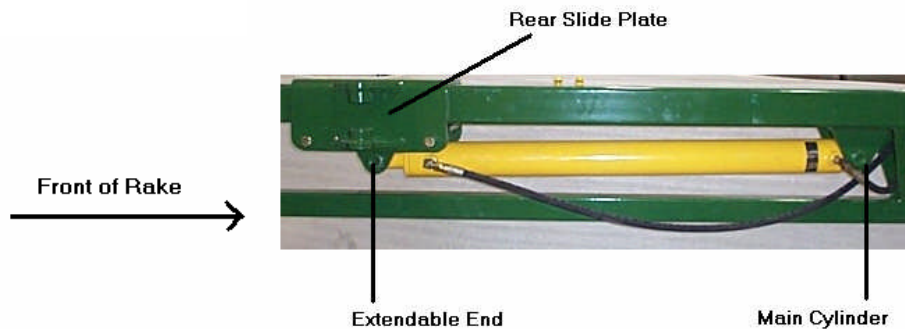

7.15 Rear Scissor Arm

The next step is to mount the rear scissor arm to the Frame Slides and riser arm. The rear scissor arm can be told from the front scissor arm by the length of the arms. The rear arms are shorter than the front arms. Place one end of the scissor arm into the mounting bracket of the rear Frame Slides. Secure the scissor arm into place using the mounting pin ($5 \frac{1}{4}$ " x $1 \frac{1}{8}$ ") with $\frac{1}{4}$ " x 2" roll pins.

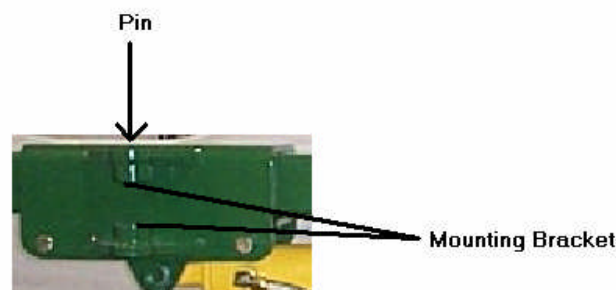



Place the rear scissor arm on top of the riser arm. Next, take the center pin (9 - 15/16" long with a small hole at either end) and place a 1/4" x 2" Roll Pin through one of the holes. Slide the washer with a 1 1/8" hole over the center pin so that it rests on the roll pin. Place the center pin through the rear scissor arm and the riser arm.

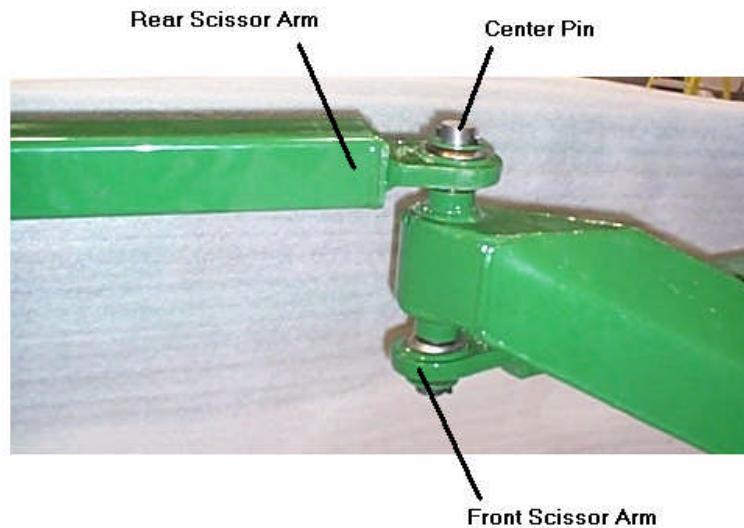

7.16 Front Scissor Arm

Now the front scissor arm can be installed. Take the front scissor arm and place one end into the mounting bracket of the front Frame Slides. Secure the scissor arm into place using the mounting pin. Secure the pin using a 1/4" x 2" roll pin. The free end of the front scissor arm is slid up onto the lower half of the center pin that is below the riser arm. Place another washer below the front scissor arm and secure the scissor arm in place by putting a 1/4" x 2" Roll Pin through the lower hole of the center pin.



7.17 Lift Rod Cylinders

To install the lift rod cylinders, the threaded rod adjuster must first be installed. The threaded rod adjuster is slid into the mounting bracket at the rear of the rake arm. The threaded adjusters are tightened until there is approximately 3" of thread sticking out the rear of the adjuster. The cylinder is bolted to the threaded rod adjuster with $\frac{1}{2}$ " x $2\frac{1}{4}$ " bolts with nylon locking nuts.

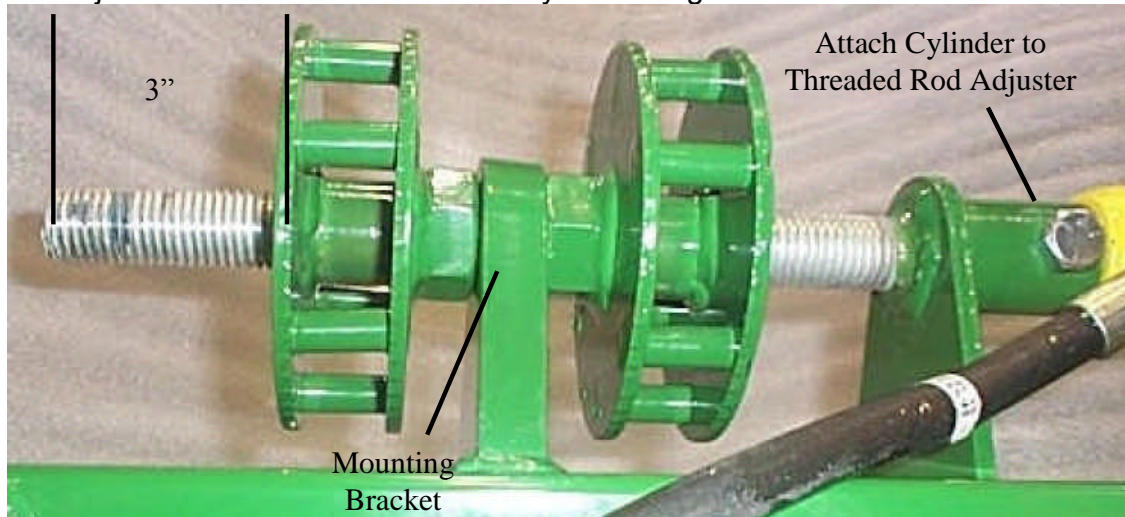

Once the lift rod cylinders are mounted they can be fitted with 90 degree hydraulic fittings. Make sure there is a $\frac{1}{32}$ " orifice hole in the cylinder before installing the cylinder.

7.18 Install Lift Rods

Now that the lift rod cylinders have been installed, the lift rods can be installed as well. The lift rods are mounted on each of the rake arms. Each of the lift rods has a fitting at one end that corresponds to the lift rod cylinder. Place this end at the lift rod cylinder. To install the lift rods slide the plastic fittings over the lift rods at the locations of the mounting brackets. Now the lift rod is slid into place with the plastic fittings at each of the mounting locations. Once the lift rod is in place, it can be attached to the lift rod cylinder, like in the picture above, using $\frac{1}{2}$ " x $2\frac{1}{4}$ " bolts with nylon locking nuts.

7.18.1 Install Lift Rod Extenders

If the optional 10 wheel extension was purchased, the lift rod extenders must now be installed as well. These extenders mount directly to the end of the regular lift rods, and are bolted together using $\frac{1}{2}$ " x $2\frac{1}{4}$ " bolts with nylon locking nuts.



7.19 Running Hoses to Lift Rod Cylinders

The next step is to run the hosing for the lift rod cylinders. The first step is to mount the T- shaped hydraulic fittings onto the two VR3 hoses that have been run through the main body. Now the hoses can be run for the lift rod cylinders, There are two hoses that are labeled VR4 and two hoses that are labeled VR5. Hook the hoses labeled VR5 onto one of the T- shaped fittings, then hook the other two hoses labeled VR4 to the other T- shaped fitting. The hoses labeled VR5 are run from the T fitting through the hose holes in the side of the rear hitch to the ram end of the cylinders. The hoses labeled VR4 are run from the T-fitting through the hose holes in the side of the rear hitch to the base end of the cylinders.

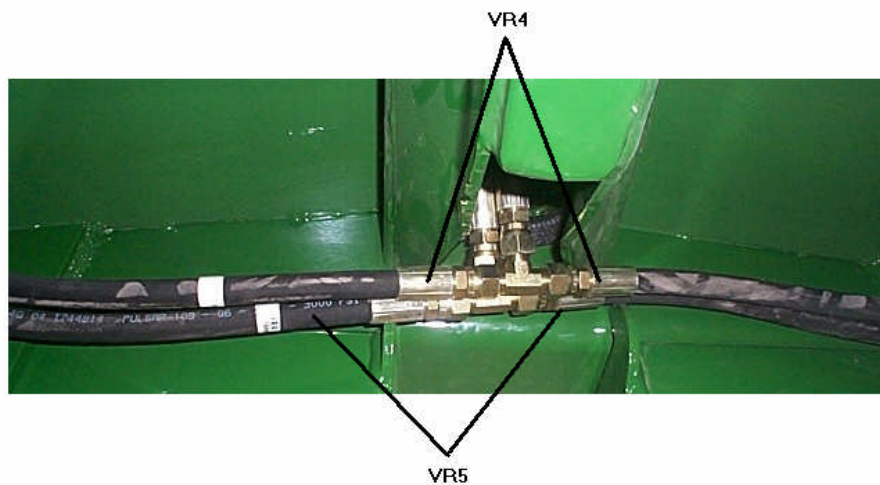

The hoses can now be mounted into the hose clips located on the rear frames. Place the hoses on either side of the hose clip bolt. Place the hose clip over the hoses and lightly tighten the clip using 3/8" nylon locking nuts. Now pull the slack of the hoses up and away from the cylinder. The hose clips can now be tightened. The hose clips keep the hoses from getting tangled in the knuckles.

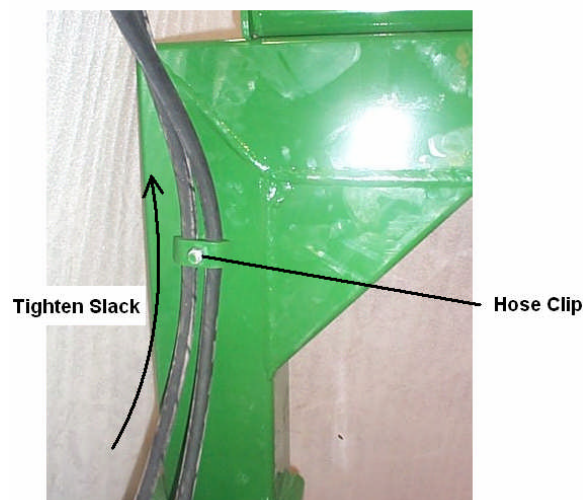



7.20 Install Rake Wheel Mounting Arm

There are 4 mounting arms for each side of the rake. The mounting arms are installed inside the rake arms with the mounting facing towards the rear of the rake. The arms are slid through the bushings and secured on the outside of the rake with a 1 1/4" inside diameter washer and 1/4" x 2" Roll Pin.

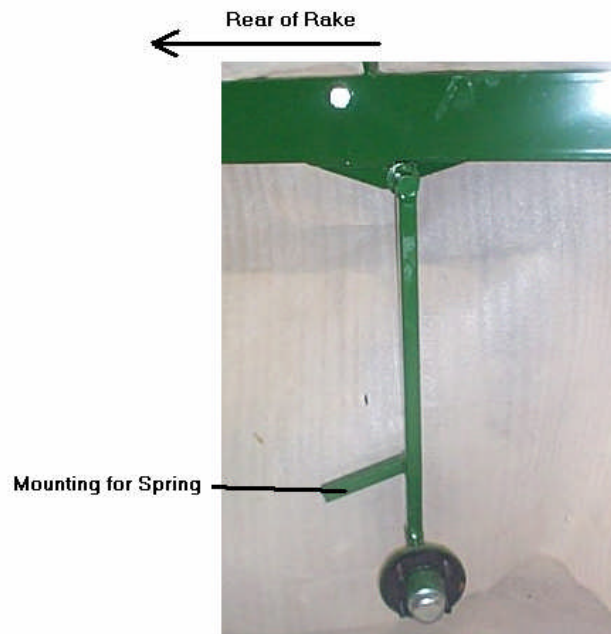

7.21 Install Spring Assembly to Mounting Arm

To mount the spring assembly, place the shaft mount into the mounting hole of the mounting arm. Now pick up the arm and secure the bolt fitting to the riser arm fitting with a 1/2" x 1 3/4" bolt with locking nut. The spring assembly will only fit if it is mounted before installing the bolt fitting.





7.22 Install Rake Wheels

The Rake Wheels are installed onto the hubs of the Rake Wheel mounting arms. There are 4 wheels for each side of the rake. Care must be taken to ensure that the wheels are mounted on the proper side of the rake. When standing at the front of the rake (at the hitch) the tines of the rake wheels will point in the direction shown below. The wheels are mounted with the wind guard facing the front of the rake.

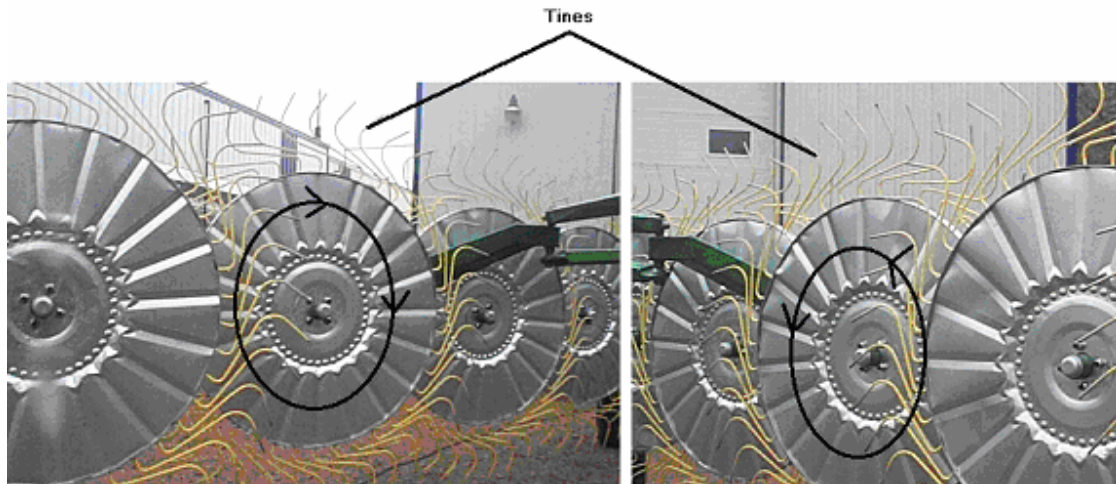

The wheels are mounted using tapered wheel nuts. FOR MOUNTING THE RAKE WHEELS THE TAPERED EDGE OF THE NUTS FACES OUT. This means that the flat edge of the nut is tightened against the Rake Wheel.



Tapered Edge Facing Out

7.23 Torque Settings

All the wheel bolts can now be tightened to their correct torque settings. These settings are:

9/16"	Dry 120 Lb.
1/2"	Dry 90 Lb.
3/4"	Dry 300 Lb.

This is the last step in assembly. The rake is now complete.